



MARINE DIESEL ENGINES



FNM HPE 110

| | |
|---------------------------------|---|
| Configuration | 4-stroke diesel, DOHC 16 V with timing chain |
| Maximum output at crankshaft | 80,8 kW/ 110 hp at 4000 rpm |
| Maximum torque | 216 Nm at 2200 rpm |
| Displacement | 1248 c.c. |
| Bore x stroke | 69.6 x 82 mm |
| Cylinders | 4, in line |
| Injection system | Direct Injection Common rail |
| Aspiration | Supercharged with variable geometry turbo |
| Starting system | Electric starting 12 V - 1.3 kW |
| Alternator | 14 V - 75 A |
| Cooling system | Double water cooling system with heat exchanger |
| Lubrication system | Forced lubricating system with pump |
| Max mounting inclination | 10° |
| Dry weight without transmission | 178 kg |
| Environmental | RCD 2003/44/CE ed EPA TIER 2 |
| Engine mounting | Rubber type anti-vibration mounting |

Power according ISO 8665, tolerance 5%, Diesel fuel according EN 590

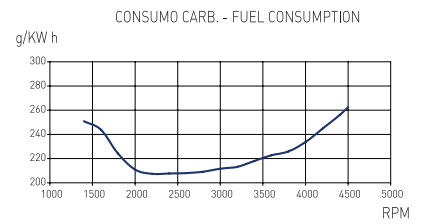
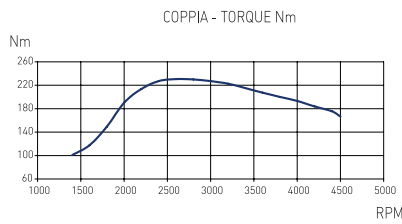
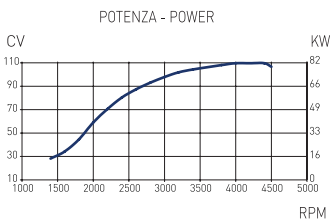

Dimensions (For detailed line-drawings, please refer to our website www.fnm-marine.com)

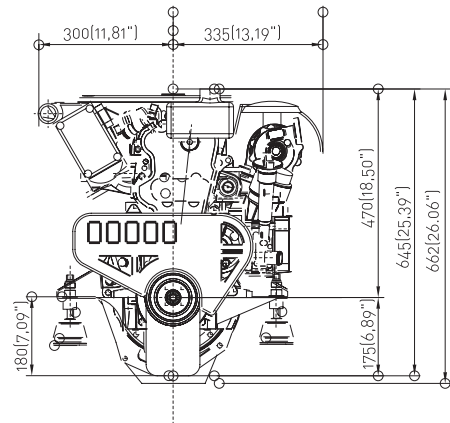
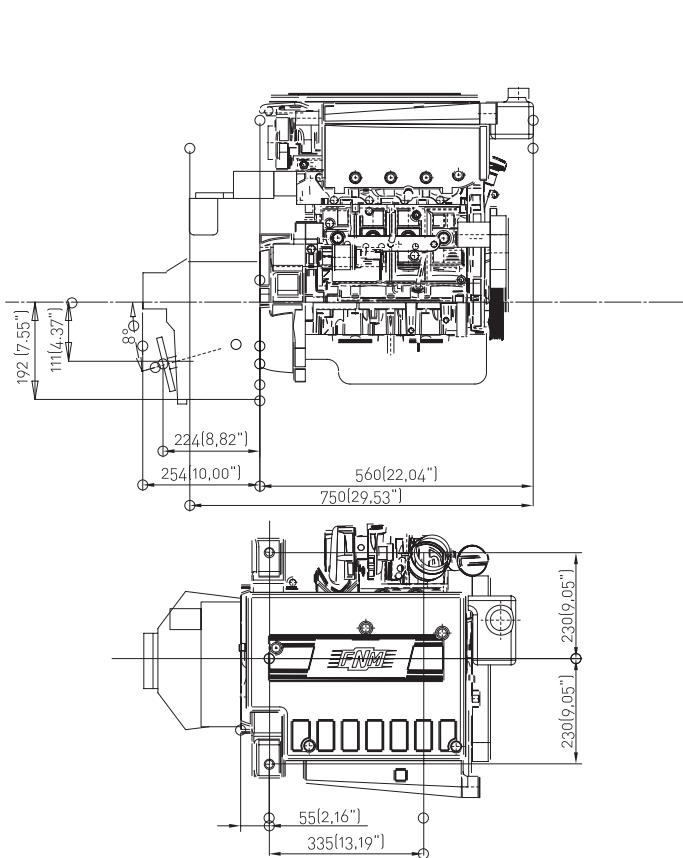

FNM HPE 110 with ZF 25 A gearbox

10/2009

Panel instrument:

- Oil pressure
- Water temperature
- Voltmeter
- Rpm
- 8 meter cable

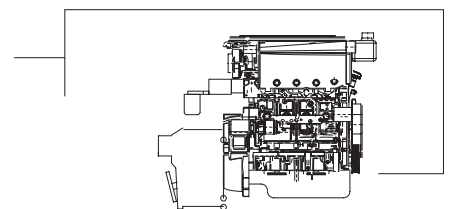

Accessories:

Standard Package

- Hydraulic gearbox
- Set of flexible mounts
- Alternator 14 V - 75 A
- Starter motor 12 V - 1,3 kW
- Fuel and oil filter

- Seawater-cooled exhaust elbow
- Racor filters
- Panel instrument with 8 mt. cable
- Seawater pump in bronze
- Engine top cover
- Water-cooled exhaust manifold

Optional

- Kit for boat internal heating
- 8 mt. auxiliary extension cable

- Flybridge instrument panel with 8 mt. cable
- Trolling valve
- 2-groove front pulley

Text and illustrations are not binding. CMD, owner of the FNM brand, reserves the right to introduce adaptations without prior notification. Vers. Eng. 15/10/08
Compliant with the RCD 2003/44/CE emission standards EPATIER 2



www.fnm-marine.com