



MARINE DIESEL ENGINES



FNM HPE 80 SAIL DRIVE

Configuration	4-stroke cycle, twin camshaft, 16 V
Maximum output at crankshaft	55 kW/ 75 hp at 3800 rpm
Maximum torque	157 Nm at 2200 rpm
Displacement	1248 c.c.
Bore x stroke	69.6 x 82 mm
Cylinders	4, in line
Combustion system	Direct injection Common Rail
Aspiration	Supercharged with variable geometry turbo
Starting system	Electric starting 12 V - 1,3 kW
Alternator	14 V - 75 A
Cooling system	Double water cooling system with heat exchanger
Lubrication system	Totally enclosed, forced lubricating system with pump
Twin Disc sail-drive model	SEAPROP 60
Gear-Reduction	Mechanical reverse system with oil-lubricated clutch
Reduction ratio	2.15
Max. revolutions at propeller	1768 rpm
Sail drive oil	ATF (about 3Kg)
Propeller rotation in forward gear	Clockwise
Dry weight (incl. transmission)	205 kg
Engine mounting	Rubber type anti-vibration mounting AMC
Environmental	RCD 2003/44/CE ed EPA TIER 2

Power according ISO 8665, tolerance 5%, Diesel fuel according EN 590

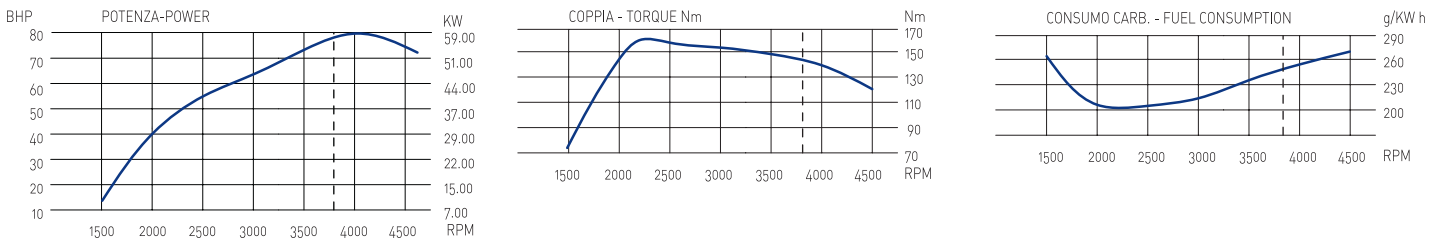

Dimensions (For detailed line-drawings, please refer to our website or contact your supplier)

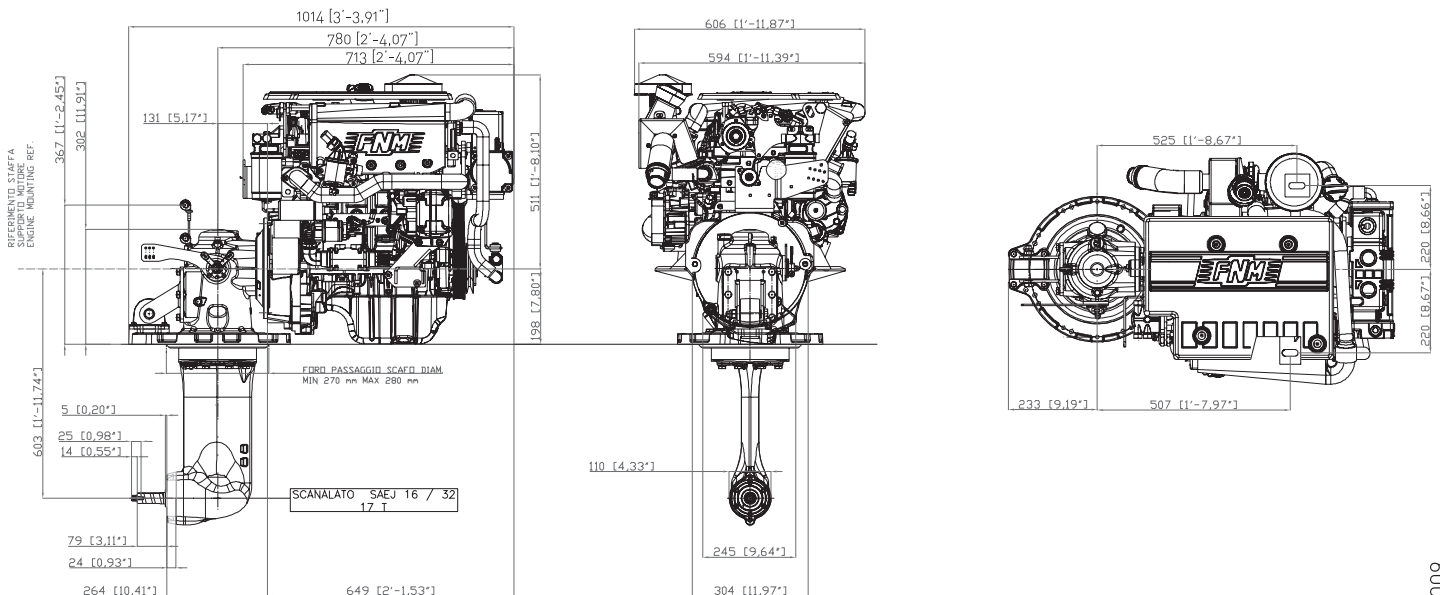

FNM HPE 80 SD with Sail Drive SP 60

EXHAUST RISER DIAMETER 60mm
 FUEL LINE INLET DIAMETER 8mm
 SEA WATER LINE INLET DIAMETER 25mm

10/2009

Panel instrument

- Oil Pressure
- Water Temperature
- Voltmeter
- RPM Counter
- 8 meter cable

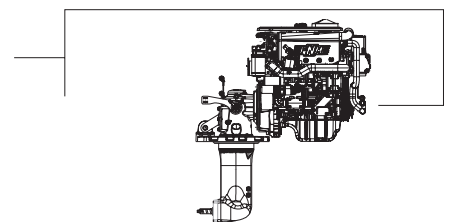

Accessories

Standard Package

- Sail drive model SP 60
- Set of flexible mounts
- Alternator 14 V - 75 A
- Starter motor 12 V - 1,3 kW

- Stainless steel seawater-cooled elbow diameter 60 mm
- Instrument panel with 8 mt. cable
- Bronze seawater pump
- Water-cooled exhaust manifold
- Racor filters
- Engine top cover

Optional

- Kit for boat internal heating
- 4 mt. auxiliary extension cable
- Spinner for fixed blade propellers

- Engine bed in polyester VTR Twin Disc
- Flange for the application without engine bed in VTR

Text and illustrations are not binding. CMD, owner of the FNM brand, reserves the right to introduce adaptations without prior notification. Compliant with the RCD 2003/44/CE and EPA TIER 2 emission standards.

